

Colloquy

- **ALSO KNOWN AS** Colloquim; Double Panel
- **CATEGORIES** Large Group
- **CLASSIFICATIONS** Discussion Technique; Information-Presentation; Oral Communication
- **DIVISIONS** Major
- **DEFINITION**

The **COLLOQUY** is often referred to as a "double panel" indicative of its two panel format. Each panel normally consists of from two to four members, one composed of outside resource persons, and the other of representatives from the audience. The latter panel presents to the former panel those questions, problems, and situations proposed by the audience which they represent, while the resource panel members answer questions, discuss issues, and present information in their specializations. The audience, likewise, is permitted and encouraged to actively participate whenever possible.

■ INSTRUCTIONS FOR USE

1. Participants on both panels are chosen in advance according to their particular qualifications.
2. The instructor (leader) appoints a moderator who introduces the subject and panel members, guides the session, and keeps the discussion flowing.
3. The panel, which is composed of audience representatives, raises problem issues and asks questions representative of the entire audience.
4. Resource persons provide appropriate information in their areas of expertise.
5. The general audience is permitted and encouraged to actively participate whenever possible (by asking questions, seeking clarification, etc.).
6. Evaluation is made of the session by discussion, or other suitable method, and a summary may be formulated by the moderator/instructor and/or the entire group.

■ BEST AGES FOR USE

The **COLLOQUY** is best used by adults, with its major usage being in a collegiate instructional setting. Adult informational gatherings may also use this methodology advantageously.

44 EDUCATIONAL SPICE

■ TIME REQUIREMENTS

A **COLLOQUY**, in its entirety, will probably last at least one hour. Preparation time, however, for the two panels may require many additional hours.

■ PERSONNEL REQUIRED

A moderator, two to four resource persons, and two to four audience representatives are required for this method in addition to the audience.

■ NECESSARY MATERIALS, EQUIPMENT & FACILITIES

Although not actually required, two tables and adequate seating for the panel members (as well as for the audience) are helpful. For large groups, a stage or elevated platform and appropriate sound amplification equipment may be necessary in order that all members of the audience may see and hear properly.

■ ADVANTAGES

1. The **COLLOQUY** allows for greater flexibility in content as the subject may be directed toward areas of concern and interest to the audience.
2. This methodology allows for at least a limited active audience participation in a large group setting.
3. It enables resource persons to better understand and satisfy the needs and desires of the audience rather than merely presenting irrelevant or uninteresting materials of interest only to the speakers.
4. Dispersed information is more authoritative, having originated with experts.
5. The **COLLOQUY** may expose the audience to information or materials otherwise unavailable to the general public.

■ DISADVANTAGES & LIMITATIONS

1. A compatible panel of experts or resource persons is often difficult, if not impossible, to assemble.
2. A skillful moderator is required.
3. Members of the resource panel may tend to ramble, or shift the topic to their respective pet interests.
4. The **COLLOQUY** is not necessarily an active participation method for the general audience, despite the fact that they do have some limited access to panel members.
5. Subject matter experts are not necessarily capable teachers or persuasive speakers.

■ DIAGRAM

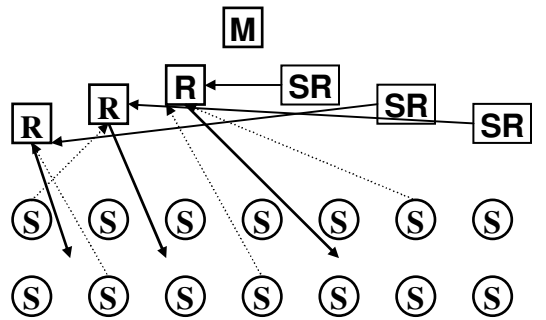

-
- M** = Moderator
 - R** = Resource Person
 - SR** = Student Representative
 - S** = Student